



## Classic Sport Ignition instruction manual

Adjustable for different curve's (max. 16, see table)

Suitable for 12 Volt; negative earth only and original ignition coil.

For 12 Volt; ignition coil more than 2,5 ohm

Please read this instruction carefully.

An incorrect installation can destroy the CSI and/or damage the engine!

In case of any doubt, please consult an expert.

Pay attention for high voltage!

### Installation:

1. Check the resistor value of the ignition coil! For 12 Volt: ignition coil more than 2,5 ohm. If the resistor value is too low it can cause overheating and/or damage the CSI.
2. Find the static adjustment point of the engine (see the workshop manual), so that the rotor points to the ignition cable of the first cylinder.
3. Remove the old ignition and place the CSI.
4. Disconnect all wires of the ignition coil. Determine the 12 Volt power supply wire and connect it to the + contact of the ignition coil together with the red wire of the CSI.  
Do not connect the other wires yet.  
If the 12 Volt will be connected directly to the black wire, the output stage will get damaged!!
5. Turn the ignition on.
6. Turn the CSI to the left until the led flashes; the number of times that the led flashed is the curve number that is currently set.
7. Adjust, with the help of a small Philips screw driver, the right curve (see table).
8. Slowly turn the ignition to the right (clockwise) until the blue led lights continuously. The CSI is now adjusted to the static adjustment point. Tighten the CSI.
9. Turn off the ignition and connect the black wire to the negative contact of the ignition coil.
10. Assemble the distributor cap and connect the ignition cable, watch the order and keep the high-voltage cables as far away as possible from the other cables (to prevent interference).
11. Connect the vacuum hose (if present)
12. Put the car in neutral and start the engine.
13. The possible wire of the tachometer can now also be connected to the black wire.
14. Check the adjustment with the help of a stroboscope and a workshop manual.

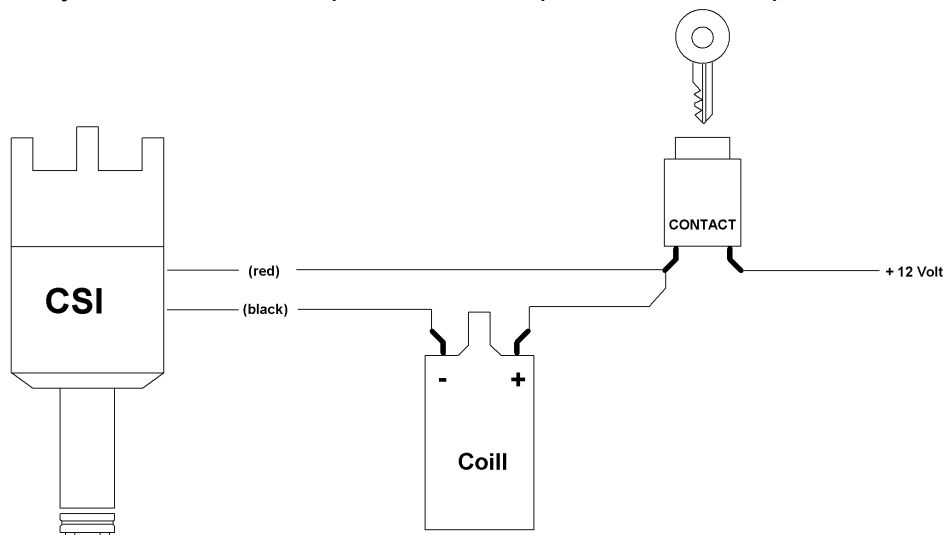

For the latest updates and additions please advise: [www.csi-ignitions.com](http://www.csi-ignitions.com)